



|   | Half Moon Downlight W                 | Half Moon Downlight RGBW /DW |
|---|---------------------------------------|------------------------------|
| Code / Codice   | AL5319                                |                              |
| Power consumption<br>Consumo di energia               | 3W                                    | 2W                           |
| Remote Power supply<br>Alimentatore Remoto            | Constant Current: 900mA               | Constant Current: 200mA      |
| Input Voltage<br>Tensione di alimentazione            | 3.2 V                                 |                              |
| Electrical class<br>Classe elettrica                  | III                                   |                              |
| Weight / Peso   | Half Moon Downlight: 0.2 Kg / 0.44 lb |                              |
| Operating temperature<br>Temperatura di funzionamento | -40°C to 40°C / (-40°F to 104°F)      |                              |
| IP rating / Grado IP                                  | IP66                                  |                              |
| IK rating / Grado IK                                  | IK10                                  |                              |

### Size / Dimensioni

#### HALF MOON DOWNLIGHT TRIM - WHITE LIGHT

#### HALF MOON DOWNLIGHT TRIMLESS - WHITE LIGHT

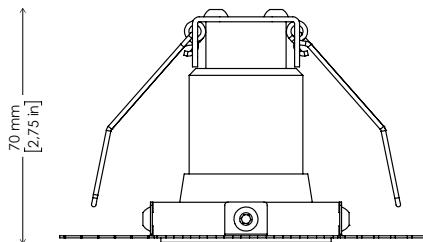
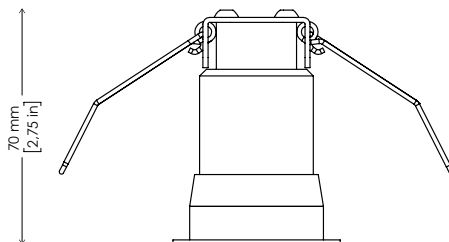
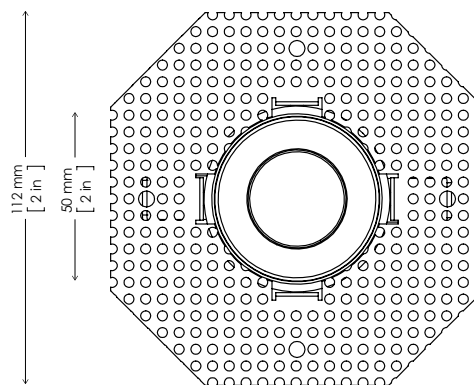
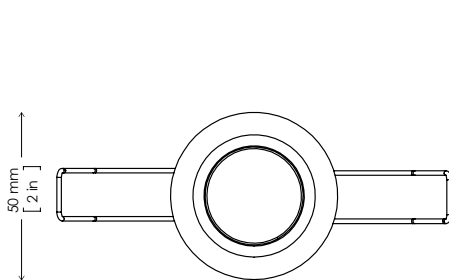

Ø 44mm



Ø 64mm

 Thickness of plasterboard: from 10 to 25 mm  
Spessore del cartongesso: da 10 a 25 mm

 Thickness of plasterboard: from 10 to 25 mm  
Spessore del cartongesso: da 10 a 25 mm

## Size / Dimensioni

HALF MOON DOWNLIGHT TRIM RGBW and DW

HALF MOON DOWNLIGHT TRIMLESS RGBW and DW

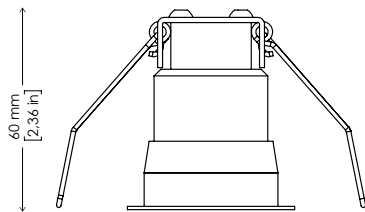
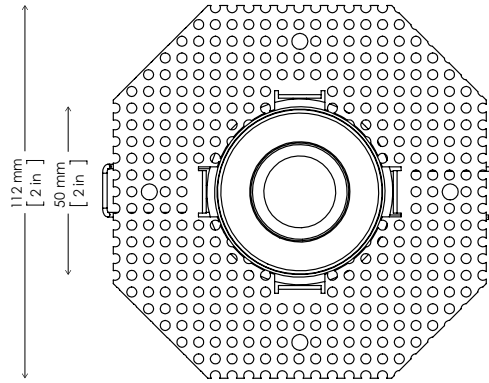
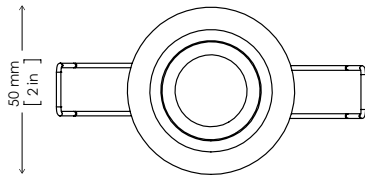

Ø 44mm

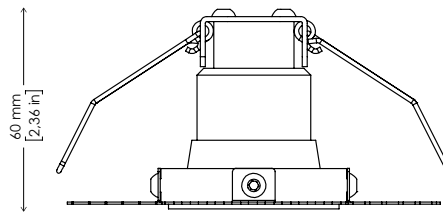

Ø 64mm

1  Thickness of plasterboard: from 10 to 25 mm  
Spessore del cartongesso: da 10 a 25 mm

1  Thickness of plasterboard: from 10 to 25 mm  
Spessore del cartongesso: da 10 a 25 mm

## Important notices/Avvertimenti importanti

- This product must be installed in accordance with applicable national and local electrical and construction codes by a person familiar with the construction and operation of the product and the hazards involved. Failure to comply with the following installation instructions may result in death or serious injury. Questo prodotto deve essere installato secondo le normative locali, da personale specializzato. La mancata osservanza delle istruzioni di installazione può portare a situazioni di pericolo all'incolumità della persone.

- Do not stare at the operating light source.

Non fissare la sorgente luminosa durante il suo funzionamento.

- The fixture might be damaged by excess voltage. The installation of an overvoltage protection device on the electrical system may reduce the risk of damage.

Apparecchiatura sensibile alle sovratensioni. L'installazione di un dispositivo di protezione delle sovratensioni sull'impianto elettrico attenua l'intensità di questi fenomeni proteggendo gli apparecchi dal rischio che vengano danneggiati.

- The use of an adequate magnetothermic switch along the power supply line is recommended.

E' consigliato l'uso di un adeguato interruttore magnetotermico/differenziale sulla linea di alimentazione.

- Connect the fixtures to each other only when disconnected from mains.

Collegare tra loro i proiettori solo quando nessuno di essi è collegato alla rete elettrica.

- Never leave cables and connectors unconnected or unprotected for long periods.

Non lasciare mai per lungo tempo agli agenti atmosferici cavi e connettori non collegati o non protetti.

- Disconnect power before installing or servicing to avoid electrical shock.

Togliere l'alimentazione prima di effettuare qualsiasi operazione all'interno dell'apparecchiatura.

- Disconnect power before any connection operation.

Togliere l'alimentazione prima di effettuare qualsiasi operazione di connessione tra gli apparecchi.

- Check voltage and frequency before powering the fixture. Do not exceed fixture specified voltage.

Prima di connettere l'apparecchio alla rete elettrica, verificate la compatibilità di tensione e frequenza.

- Do not handle the unit with wet hands or in wet environments.

Non maneggiate il prodotto con mani bagnate o in presenza di acqua.

- Apply to qualified staff for any maintenance service not described in this instructions manual.

Rivolgersi ad un tecnico qualificato per qualsiasi operazione di manutenzione ordinaria non descritta nel presente manuale.

- Do not exceed the maximum quantity of fixtures per line in order to avoid power surges.

Non superare il numero massimo specificato di apparecchi per linea per evitare pericoli sovraccarichi di corrente.

- Before powering the unit, ensure to use cables and connectors with proper section and length, according to its power consumption.

Prima di effettuare le connessioni verificare la portata dei cavi / connettori e la lunghezza dei cavi tenendo conto dell'assorbimento del prodotto.

- Fix the projector by using screws, hooks or other adequate supports that can bear its weight.

Fissare il proiettore con viti, ganci o altri supporti in grado di sostenerne il peso.

- All devices connected to the DALI bus must be SELV type.

Tutte le apparecchiature connesse al bus DALI devono essere di tipo SELV.



**CAUTION: Prolonged staring at the LED source should be avoided by placing the fixture in a proper position.**

**ATTENZIONE! Fissare la sorgente LED per un periodo prolungato va evitato posizionando l'apparecchio nella posizione appropriata.**



**WARNING ! Fixing and connecting operations must mandatorily be carried out by qualified personnel only !**

**ATTENZIONE ! Le operazioni di fissaggio e collegamento devono essere eseguite solo e obbligatoriamente da personale qualificato!**



**WARNING ! Make sure that power supply is off before connecting or disconnecting fixtures !**

**ATTENZIONE ! Assicurarsi che l'alimentazione sia spenta prima di collegare o scollegare i dispositivi!**



**WARNING ! Fixtures are not suitable to be covered in thermally -insulating material.**

**ATTENZIONE ! Gli apparecchi non sono idonei ad essere ricoperti da materiale termicamente isolante.**



**WARNING ! Check that the false ceiling supports the static load of the devices to be installed**

**ATTENZIONE ! Verificare che il controsoffitto supporti il carico statico degli apparecchi da installare** *page 3 of 10*

## Important notices/Avvertimenti importanti



The possibility of reusing some electrical parts of the device is subject to the total responsibility of the user. The label shows the symbol indicated in Legislative Decree n.49 of 14 March 2014 which transposes Directive 2012/19 / EU, which indicates the need to dispose of the product in separate waste, specifically in electrical waste, and electronic. Refer to the waste collection center located in your area.



La possibilità di riutilizzare alcune parti elettriche del dispositivo è subordinata alla totale responsabilità dell'utilizzatore. Nell'etichetta è stato riportato il simbolo indicato nel D.lgs n.49 del 14 Marzo 2014 che recepisce la direttiva 2012/19/UE, il quale indica la necessità di smaltire il prodotto nei rifiuti differenziati, nello specifico nei rifiuti di tipo elettrico ed elettronico. Fare riferimento al centro di raccolta rifiuti situato nella Vostra zona.



Replaceable control gear by a professional



Alimentatore sostituibile da un professionista



Replaceable (LED only) light source by a professional



Sorgente luminosa (solo LED) sostituibile da un professionista



Warning! Risk of electric shock



Attenzione pericolo di scossa elettrica

This product contains a light source of energy efficiency class: F

Questo prodotto contiene una sorgente luminosa di classe di efficienza energetica:F

## Fixing / Fissaggio

**⚡ WARNING ! fixing and connecting operations must mandatorily be carried out by qualified personnel only !**  
**ATTENZIONE ! le operazioni di installazione e connessione devono obbligatoriamente essere eseguite solo da personale specializzato !**

**⚠ WARNING ! Ensure power supply is off before connecting or disconnecting fixtures !**  
**ATTENZIONE ! Assicurarsi che l'alimentazione sia disattivata prima di collegare o scollegare i proiettori!**

**Note:** The fixture can be installed horizontally in false ceiling and vertically on walls

**Nota:** L'apparecchio può essere installato orizzontalmente nel controsoffitto e verticalmente a parete.

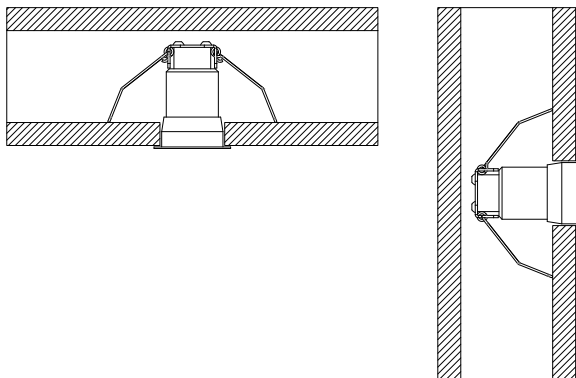

### HALF MOON DOWNLIGHT TRIM

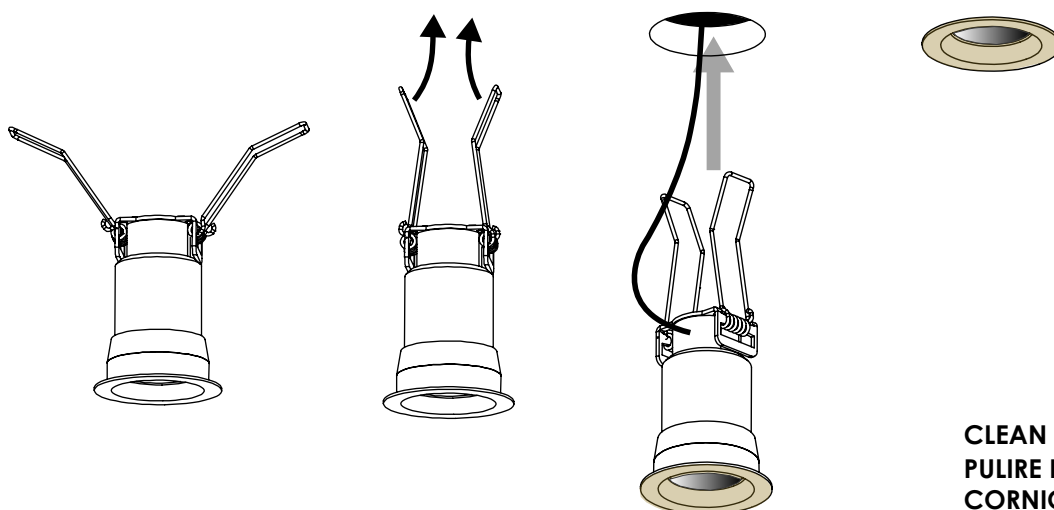

**CLEAN INSIDE THE FIXING FRAME**  
**PULIRE INTERNAMENTE ALLA**  
**CORNICE DI FISSAGGIO**

### HALF MOON DOWNLIGHT TRIMLESS

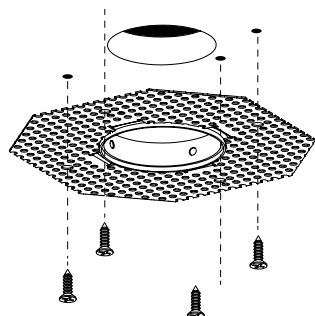

**TSP SELF TAPPING SCREW 2,9x15**  
**VITE AUTOFILETTANTE TSP 2,9x15**

**PLASTER AND SAND**  
**STUCCARE E CARTEGGIARE**

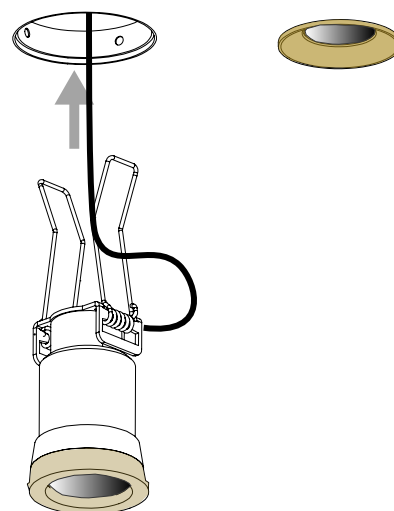
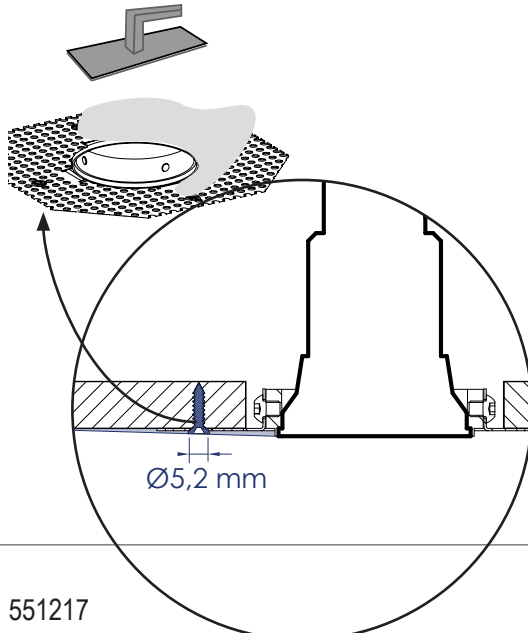

**Dimensioning false ceiling**  
**Dimensionamento controsoffitto**

Minimum dimensions of the false ceiling space, and minimum distances from fixture to the PSU and from fixture to the vertical walls.

Dimensioni minime del vano del controsoffitto e distanze minime dall'apparecchio all'alimentatore e dalle apparecchio alle pareti verticali.

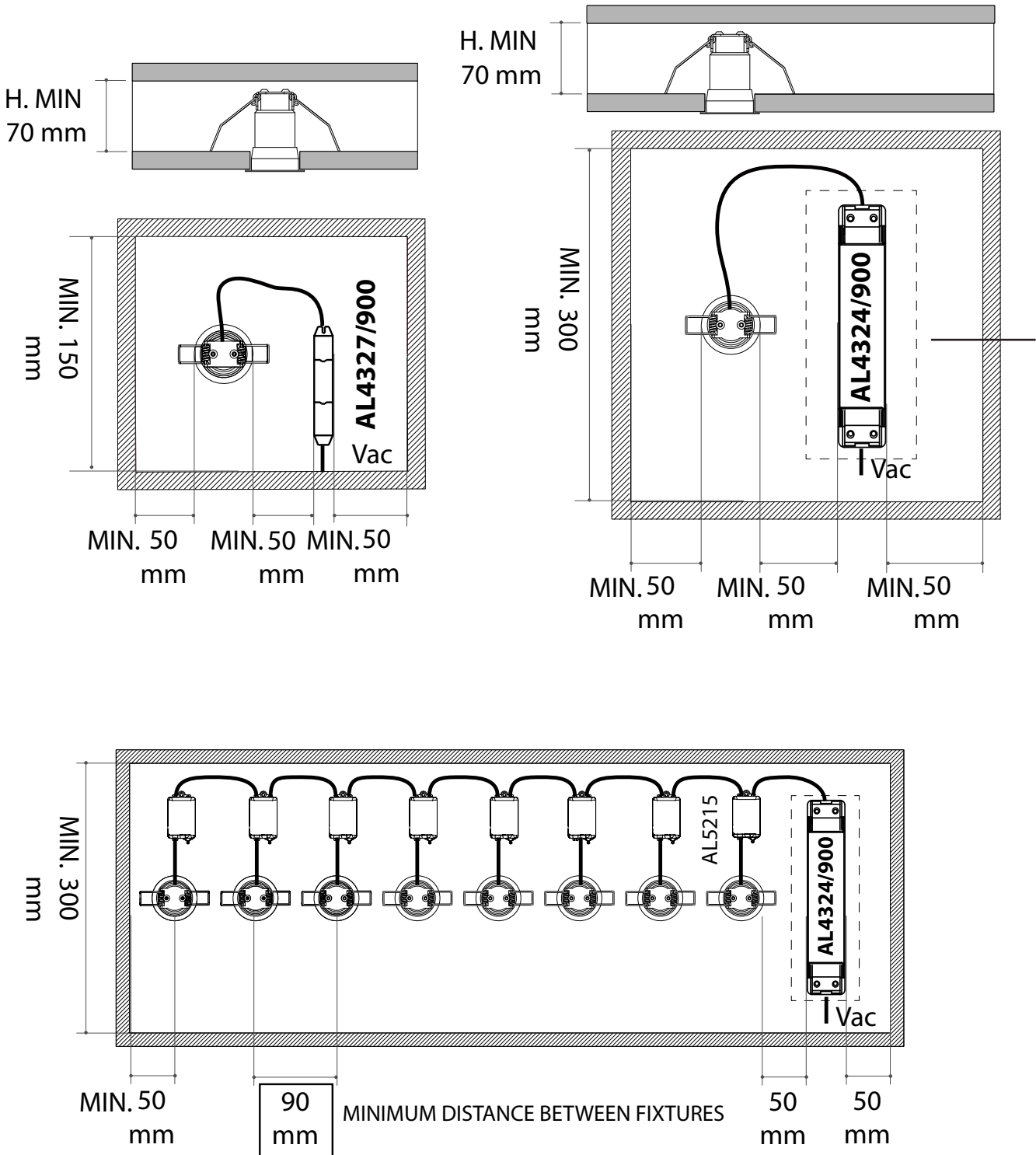

Dimensioning false ceiling  
 Dimensionamento controsoffitto

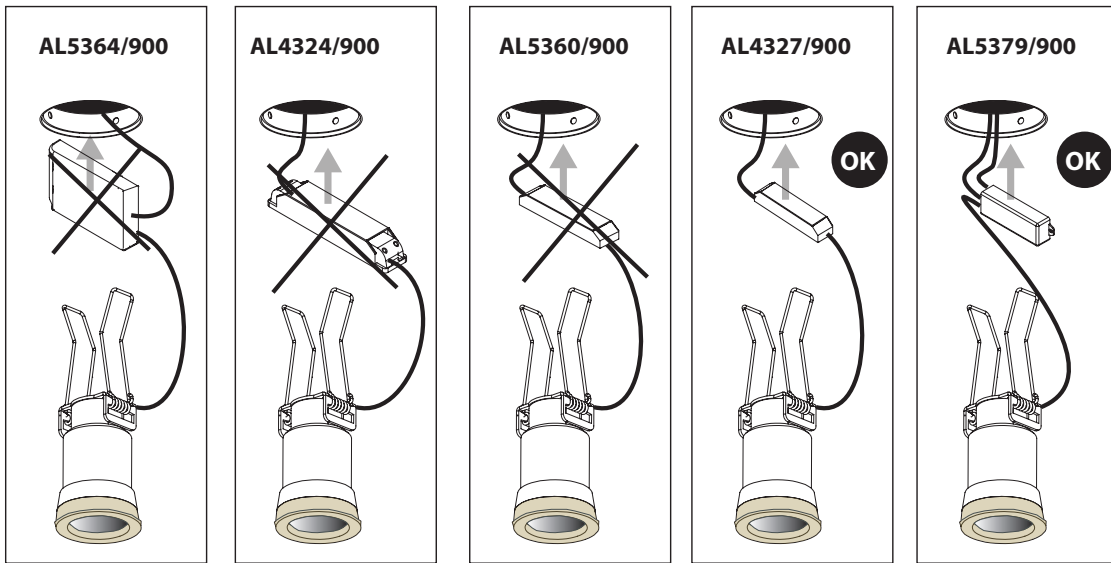
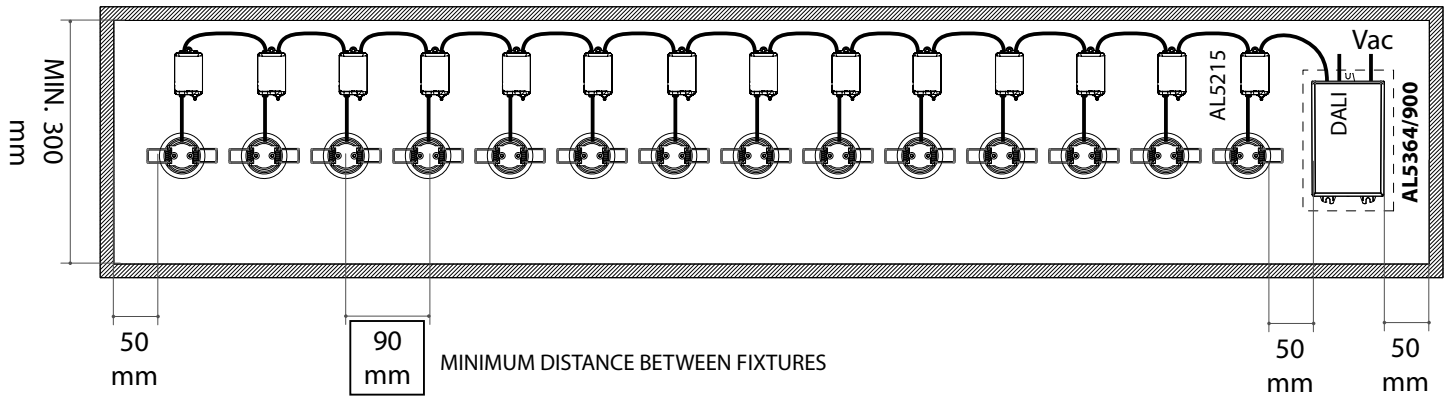

HALF MOON DOWNLIGHT WHITE LIGHT

Cable type ( Power in ) - 2x0,25 mm<sup>2</sup>  
 Tipo di cavo ( Power in ) - 2x0,25 mm<sup>2</sup>

Cable type ( Power in ) - 2x0,25 mm<sup>2</sup>  
 Tipo di cavo ( Power in ) - 2x0,25 mm<sup>2</sup>

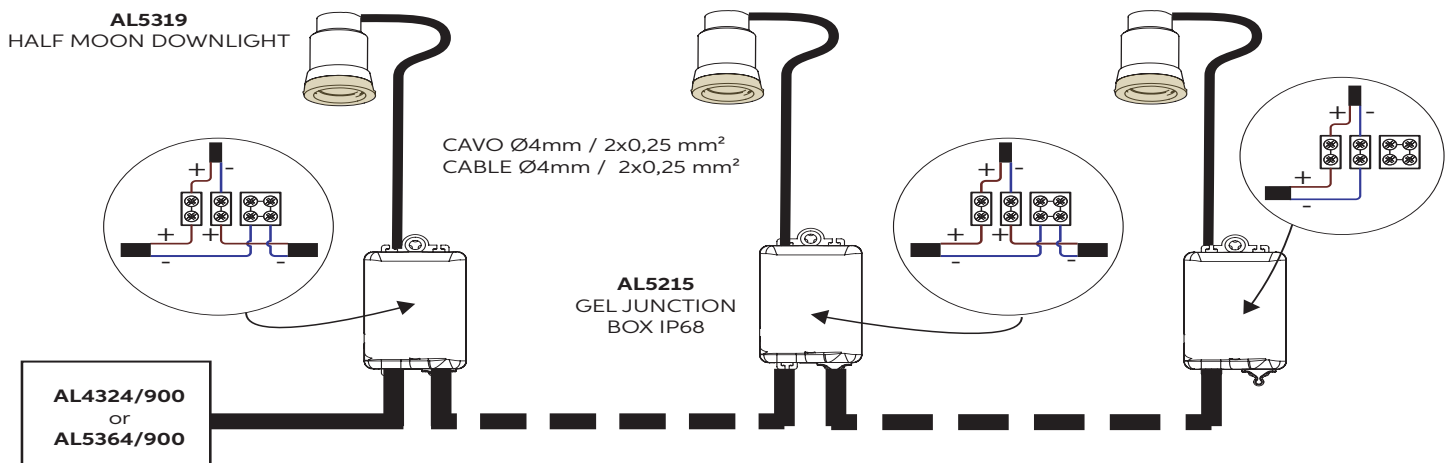
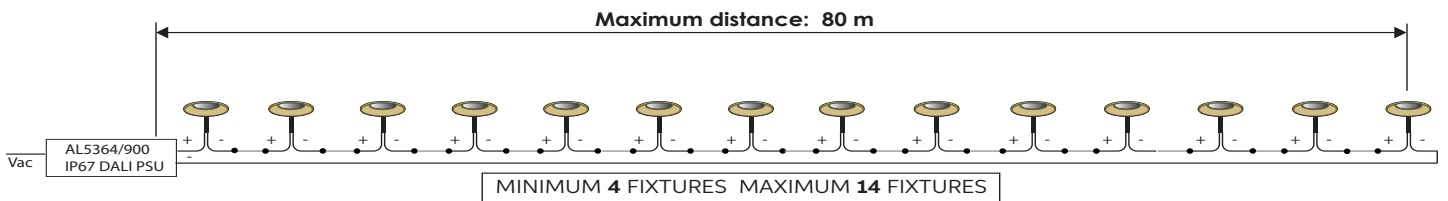
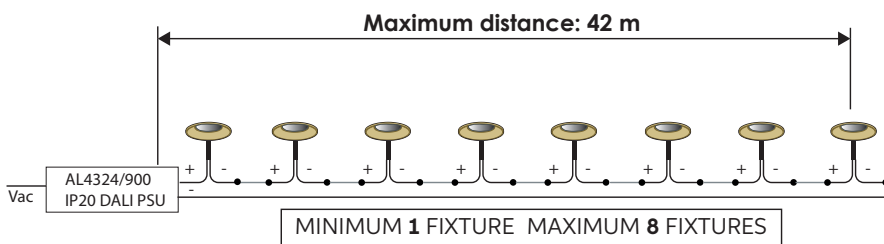
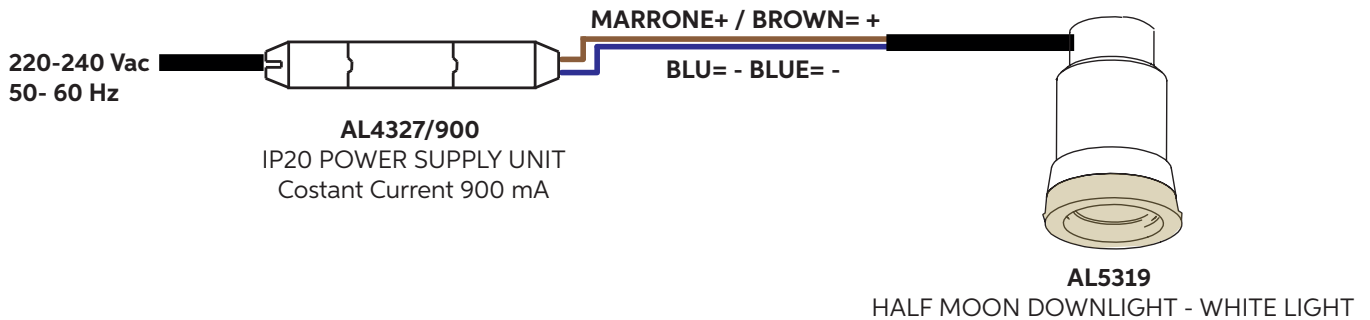

| CABLE/CAVI     | USE/UTILIZZO |
|----------------|--------------|
| BROWN/ MARRONE | +            |
| BLUE/BLU       | -            |

Make only waterproof connections through IP67 junction boxes  
 Effettuare solo connessioni stagne attraverso scatole di derivazione IP67





# HALF MOON DOWNLIGHT RGBW LIGHT

Cable type ( Power in ) - 8x0,25 mm<sup>2</sup>  
 Tipo di cavo ( Power in ) - 8x0,25 mm<sup>2</sup>

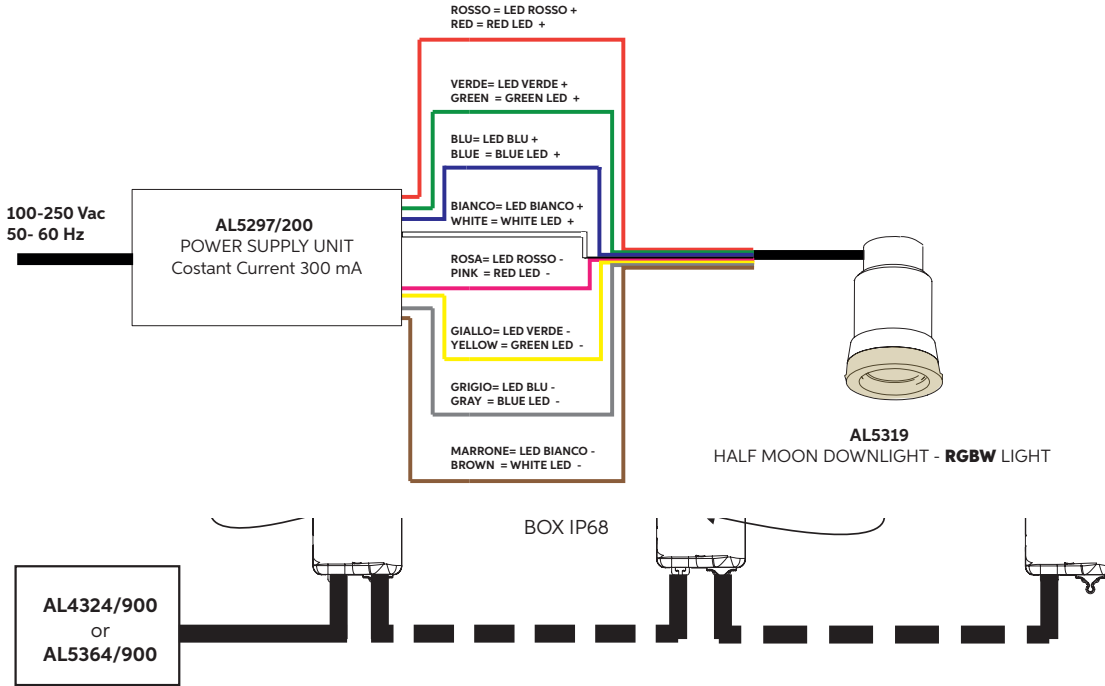

| CABLE/CAVI     | USE/UTILIZZO |
|----------------|--------------|
| BROWN/ MARRONE | +            |
| BLUE/BLU       | -            |

**MAXIMUM 10 FIXTURES**  
 Distance between PSU and last fixture: 100m

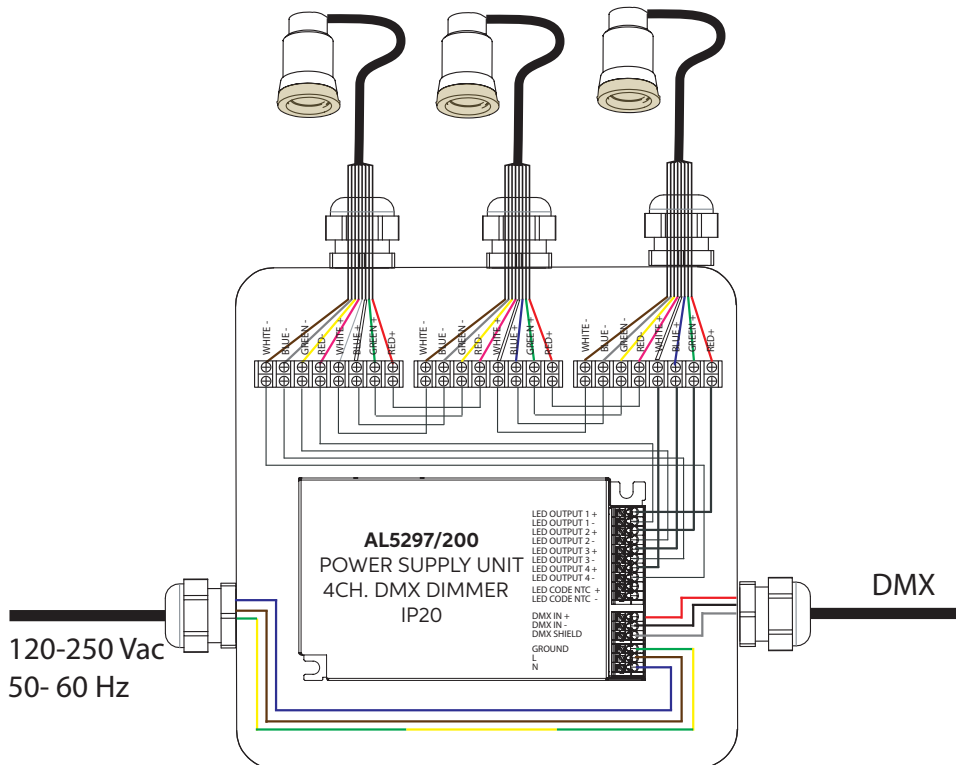

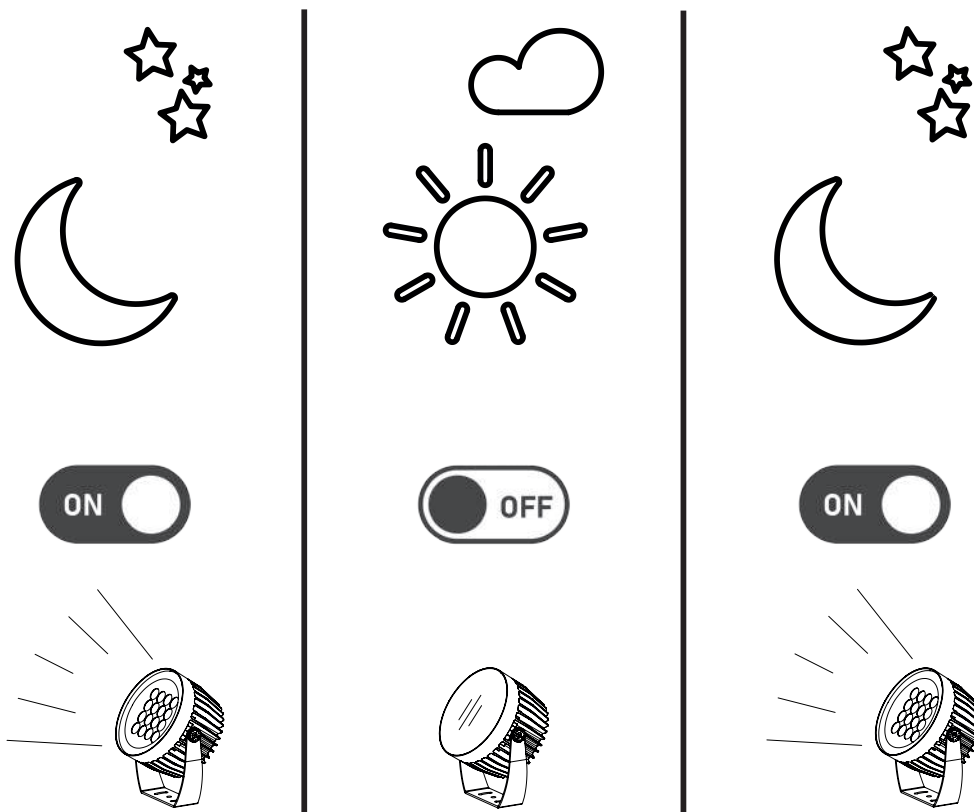

**Note:** Allowed operation only between sunset and sunrise

**Nota:** Accensione dell'apparecchio ammessa soltanto tra gli orari di tramonto e alba  
Remote PSU / Alimentatori Esterni

| WHITE LIGHT         |         |                          |  |  |                             |   |
|---------------------|---------|--------------------------|--|--|-----------------------------|---|
| Forward voltage led | Current | Code                     | Description  | PSU IP20 ONLY ON/OFF (no dimming)                            | PSU IP20                    | PSU IP67                                  |
| 35V                 | 250mA   | AL5309 / AL5327          | Moon Marine W  | N.A  | AL5295/250 (DALI) (1-3pcs)  | AL5363/250 (DALI) (1pc)                   |
| 35V                 | 250mA   | AL5311 / AL5325          | Moon Recessed W / Moon Recessed Adjustable W                     | N.A  | AL5295/250 (DALI) (1-3pcs)  | AL5363/250 (DALI) (1pc)                   |
| 35V                 | 350mA   | AL5310 / AL5312 / AL5314 | Moon W   | AL5360/350 (ON/OFF) (1pc)                                    | AL5295/350 (DALI) (1-3pcs)  | AL5363/350 (DALI) (1pc)                   |
| 3V                  | 700mA   | AL5317                   | Half Moon Recessed W   | AL5360/700 (ON/OFF) (1-12pcs)                                | AL4324/700 (DALI) (1-9pcs)  | L5363/700 (DALI) (4-14pcs)                |
| 3V                  | 800mA   | AL5309 / AL5327          | Moon Marine Ultraspot W  | AL5360/800 (ON/OFF) (1-12pcs)                                | AL4324/800 (DALI) (1-8pcs)  | AL5364/800 (DALI and 0/1..10V) (4-14pcs)  |
| 3V                  | 800mA   | AL5311 / AL5325          | Moon Recessed Ultraspot W / Moon Recessed Adjustable Ultraspot W | AL5360/800 (ON/OFF) (1-12pcs)                                | AL4324/800 (DALI) (1-8pcs)  | AL5364/800 (DALI and 0/1..10V) (4-14pcs)  |
| 3V                  | 900mA   | AL5315/ AL5316 / AL5318  | Half Moon W  | AL5360/900 (ON/OFF) (2-12pcs)                                | AL4324/900 (DALI) (1-8pcs)  | AL5364/900 (DALI and 0/1..10V) (4-14pcs)  |
| 3V                  | 900mA   | AL5324 / AL5326          | Half Moon Marine W   | AL5360/900 (ON/OFF) (2-12pcs)                                | AL4324/900 (DALI) (1-8pcs)  | AL5364/900 (DALI and 0/1..10V) (4-14pcs)  |
| 3V                  | 1000mA  | AL5310 / AL5312 / AL5314 | Moon Ultraspot W   | AL5360/1000 (ON/OFF) (1-12pcs)                               | AL4324/1000 (DALI) (1-8pcs) | AL5364/1000 (DALI and 0/1..10V) (4-14pcs) |
| 3V                  | 900mA   | AL5319                   | Half Moon Downlight W  | AL5360/900 (ON/OFF) (2-12pcs)<br>AL4327/900 (ON/OFF) (1 pcs) | AL4324/900 (DALI) (1-8pcs)  | AL5364/900 (DALI and 0/1..10V) (4-14pcs)  |
| 35V                 | 300mA   | AL5313                   | Moon Downlight W   | AL5360/300 (ON/OFF) (1pc)                                    | AL5295/300 (DALI) (1-3pcs)  | AL5363/300 (DALI) (1pc)                   |
| RGBW LIGHT          |         |                          |  |  |                             |   |
|                     | 300 mA  | AL5315/ AL5316 / AL5318  | Half Moon RGBW / DW  |  | AL5297/300 (DMX) (1-10pcs)  | N.A                                       |
|                     | 150mA   | AL5317                   | Half Moon Recessed RGBW / DW                                     |  | AL5297/150 (DMX) (1-10pcs)  | N.A                                       |
|                     | 200mA   | AL5319                   | Half Moon Downlight RGBW / DW                                    |  | AL5297/200 (DMX) (1-10pcs)  | N.A                                       |